



**ROBERT M. ARNOLD PUBLIC HEALTH SCIENCES BUILDING
THE FRED HUTCHINSON CANCER RESEARCH CENTER
SEATTLE, WASHINGTON**

**TECHNICAL REPORT 2:
INVESTIGATION AND ANALYSIS INTO EXISTING & ALTERNATIVE FLOOR SYSTEMS**

JONATHAN P. WILLIAMS
ARCHITECTURAL ENGINEERING
STRUCTURAL



EXECUTIVE SUMMARY

THE ROBERT M. ARNOLD PUBLIC HEALTH SCIENCES BUILDING WAS CONSTRUCTED ON THE CAMPUS OF THE FRED HUTCHINSON CANCER RESEARCH CENTER (FHCRC). THE PUBLIC HEALTH SCIENCES BUILDING HOUSES FOUR PROGRAMS: EPIDEMIOLOGY, CANCER BIOLOGY, BIOSTATISTICS & MATHEMATICS, AND CANCER PREVENTION. THE PURPOSE OF THIS REPORT IS TO PROVIDE AN INTRODUCTION AND INITIAL INVESTIGATION OF THE STRUCTURAL FLOOR SYSTEM USED FOR ARNOLD BUILDING. INCLUDED IN THE REPORT ARE DETAILED DESCRIPTIONS OF THE VARIOUS ELEMENTS WHICH MAKE UP THE STRUCTURAL SYSTEM OF THE BUILDING.

THE STRUCTURE OF ROBERT M. ARNOLD BUILDING HAS VARIOUS DIFFERENT ELEMENTS. THE FLOOR SYSTEM IS COMPOSED PRIMARILY OF TWO WAY SLABS. THESE SLABS TRANSFER THE LOAD TO WHAT ARE TYPICALLY CONCRETE COLUMNS. AT THE BASE OF THE COLUMNS THE LOADS ARE THEN TRANSFERRED TO SPREAD FOOTINGS. LATERAL LOADS ARE RESISTED BY A COMBINED SYSTEM OF SHEAR WALLS AND BRACED FRAMES.

THE TYPICAL EXISTING FLOOR SYSTEM IS A TWO-WAY POST-TENSIONED FLOOR SLAB WITH DROP PANELS. WHILE THIS IS A VERY EFFICIENT DESIGN, FOUR ALTERNATIVE FLOOR SYSTEMS WERE EXAMINED. THE PRELIMINARY DESIGNS OF THESE PROPOSED STRUCTURAL SYSTEMS DETERMINED THAT THE EXISTING FLOOR SYSTEM IS ONE OF THE BEST CHOICES. OF THE PROPOSED ALTERNATIVES, THE COMPOSITE SYSTEM IS THE ONE WITH THE MOST POTENTIAL AND SHOULD BE EXPLORED FURTHER.

TABLE OF CONTENTS

1	CODE REQUIREMENTS
2	LOAD DETERMINATION
5	DESCRIPTION OF STRUCTURAL SYSTEM
7	EXISTING FLOOR SYSTEM
9	ALTERNATE SYSTEM 1: COMPOSITE
11	ALTERNATE SYSTEM 2: PRE-CAST, PRE-STRESSED CONCRETE
13	ALTERNATE SYSTEM 3: ONE-WAY CAST IN PLACE CONCRETE
15	ALTERNATE SYSTEM 4: TWO-WAY CAST IN PLACE CONCRETE WITH DROP PANELS
17	COMPARISON OF FLOOR SYSTEMS

LIST OF FIGURES

2-1	TYPICAL EXISTING BAY	P. 7
2-2	EXISTING DROP PANEL DETAIL	P. 7
2-3	EXISTING POST-TENSIONING TENDON PROFILE	P. 8
2-4	EQUIVALENT LOAD DIAGRAM	P. 8
2-5	EXISTING FRAMING LAYOUT	P. 8
2-6	TYPICAL COMPOSITE BAY	P. 9
2-7	COMPOSITE BEAM	P. 9
2-8	COMPOSITE GIRDER	P. 10
2-9	TYPICAL PRE-CAST LAYOUT	P. 11
2-10	PRE-CAST FLOOR PANELS	P. 11
2-11	PRE-CAST BEAM	P. 12
2-12	TYPICAL CAST-IN-PLACE (ONE-WAY) LAYOUT	P. 13
2-13	CAST-IN-PLACE BEAM	P. 13
2-14	CAST-IN-PLACE GIRDER	P. 13
2-15 (A)	CAST-IN-PLACE GIRDER SHEAR REINFORCEMENT DETAIL	P. 14
2-15 (B)	CAST-IN-PLACE GIRDER FLEXURE REINFORCE- MENT DETAIL	P. 14
2-16 (A)	CAST-IN-PLACE BEAM SHEAR REINFORCEMENT DETAIL	P. 14
2-16 (B)	CAST-IN-PLACE BEAM FLEXURE REINFORCEMENT DETAIL	P. 14
2-17	TYPICAL CAST-IN-PLACE (TWO-WAY) LAYOUT	P. 15
2-18	DROP PANEL DETAIL	P. 15

LIST OF TABLES

2-1	DEAD LOADS	P. 2
2-2	LIVE LOADS	P. 3
2-3	FLOOR SYSTEMS COMPARISON	P. 17

CODE REQUIREMENTS:

THE ROBERT M. ARNOLD BUILDING WAS DESIGNED AND COMPLETED PRIOR TO THE CITY OF SEATTLE'S ADOPTION OF THE INTERNATIONAL BUILDING CODE (IBC). THE APPLICABLE BUILDING CODE, WHEN THE BUILDING WAS DESIGNED, WAS THE 1997 UNIFORM BUILDING CODE (UBC) AS AMENDED BY THE DEPARTMENT OF PLANNING AND DEVELOPMENT. THE DESIGN OF CONCRETE STRUCTURES SHALL ALSO BE IN ACCORDANCE WITH STANDARDS SET FORTH BY THE AMERICAN CONCRETE INSTITUTION (ACI). THE SEATTLE BUILDING CODE IS COMPRISED OF THE 1997 UNIFORM BUILDING CODE AND THE AMENDMENTS MADE BY THE CITY OF SEATTLE. THE CURRENT BUILDING CODE IN SEATTLE IS NOW THE IBC. THESE DESIGN REQUIREMENTS WILL ALSO BE EXAMINED. FURTHER INVESTIGATIONS, ANALYSES, AND DESIGNS WILL COMPLY WITH THE CURRENT CODE. IT IS THEREFORE NECESSARY TO LOOK AT ANY DIFFERENCES BETWEEN THE DESIGN REQUIREMENTS SET FORTH BY DESIGN PROFESSIONALS, THE UBC, AND THE IBC.

THE UNIFORM BUILDING CODE REFERS TO THE AMERICAN INSTITUTE OF STEEL CONSTRUCTION (AISC) FOR DESIGN PROVISIONS OF STEEL STRUCTURES. REGARDING CONCRETE CONSTRUCTION THE UBC HAS BASED IT'S OWN PROVISIONS ON THE AMERICAN CONCRETE INSTITUTE 318 BUT HAS NOT EXPLICITLY ADOPTED THE STANDARD. CERTAIN PORTIONS OF THE UNIFORM BUILDING CODE REFERENCE SPECIFIC SECTIONS OF THE AMERICAN SOCIETY OF CIVIL ENGINEERS (ASCE) 7. ONE SPECIFIC EXAMPLE OF IS WIND DESIGN. THE SECTION OF ASCE 7 ON WIND DESIGN IS REFERENCED, HOWEVER, THE UBC SPECIFIES ITS OWN METHOD FOR DETERMINING WIND PRESSURES.

THE INTERNATIONAL BUILDING CODE REFERS TO AISC'S DESIGN PROVISIONS FOR STEEL CONSTRUCTION. THE IBC HAS ALSO ADOPTED ACI 318 FOR THE DESIGN OF CONCRETE STRUCTURES. ASCE 7 IS REFERENCED REGARDING THE MINIMUM DESIGN LOAD FOR BUILDINGS.

GRAVITY LOADS:

DEAD LOADS

AS SPECIFIED BY THE SEATTLE BUILDING CODE, THE DEAD LOADS ARE CONSIDERED TO BE, "THE WEIGHT OF ALL MATERIALS AND FIXED EQUIPMENT INCORPORATED INTO THE STRUCTURE." UNLIKE THE LIVE LOADS, THERE IS NO TABLE SPECIFIED IN THE CODE. WHERE NECESSARY MINIMUM DESIGN DEAD LOADS FROM ASCE 7 WILL BE USED.

FLOOR DEAD LOADS

DESCRIPTION

SUPERIMPOSED

MECHANICAL & ELECTRICAL ALLOWANCE	5	LB/FT ²
PARTITION LOAD	20	LB/FT ²
FLOOR FINISHES	2.5	LB/FT ²
CEILING FINISHES	2.5	LB/FT ²
TOTAL	30	LB/FT²

NON-SUPERIMPOSED

CONCRETE	150	LB/FT ³
TOTAL	150	LB/FT³
COMPOSITE CONCRETE DECK	50	LB/FT ²
TOTAL	50	LB/FT²

TABLE 2-1

LIVE LOADS

TABLE 1-1 SHOWS THE LIVE LOADS AS OBTAINED FROM THE CODE AND ALSO THOSE OBTAINED FROM THE STRUCTURAL DRAWINGS. CERTAIN LOADS ARE NOT SPECIFIED BY THE SEATTLE BUILDING CODE AND DO NOT FALL INTO A BROADER CATEGORY. THE LOADS LISTED ON THE STRUCTURAL DRAWINGS IN SOME AREAS DIFFER FROM THE CODE. FOR THE PURPOSE OF ANALYSIS THE LIVE LOADS DETERMINED BY THE DESIGN PROFESSIONALS WILL BE USED. THE STRUCTURAL ENGINEERS HAD MORE INFORMATION REGARDING BUILDING OCCUPANCY, BUILDING EQUIPMENT, AND BUILDING USE. THE OFFICE LIVE LOAD

TAKES INTO ACCOUNT THE ADDITIONAL LOADS OF FILING SYSTEMS. IN ACCORDANCE WITH THE SEATTLE BUILDING CODE REDUCTION OF LIVE LOADS ARE PERMITTED, HOWEVER, THE STRUCTURAL ENGINEERS HAVE SPECIFIED THAT THERE WILL BE NO LIVE LOAD REDUCTION FOR THE FIRST LEVEL THROUGH THE FOURTH LEVEL.

LIVE LOADS

DESCRIPTION	UNIFORM LOAD (LB/FT ²)		
	UNIFORM BUILDING CODE	STRUCTURAL DRAWINGS	INTERNATIONAL BUILDING CODE
FLOOR			
OFFICES	50	80	50
LEVELS 1—4 (OFFICE)	50	75	50
LABORATORIES	-	100	60
INTERSTITIAL	-	25	-
CORRIDORS	100	100	100
PARKING	50	50	40
SIDEWALKS & DRIVEWAYS	250	250	250
ROOF			
ROOF	25	25	20

TABLE 2-2

DESCRIPTION OF STRUCTURAL SYSTEM:

THE ROBERT M. ARNOLD PUBLIC HEALTH SCIENCES BUILDING IS AN INTERESTING COLLAGE OF STRUCTURAL SYSTEMS. DIFFERENT PORTIONS OF THIS BUILDING EMPLOY DIFFERENT METHODS OF SUPPORTING THE NECESSARY LOADS. THE BUILDING ITSELF CONSISTS OF FIVE STORIES ABOVE GRADE PLUS A MECHANICAL "PENTHOUSE" ON THE ROOF, WHILE ALSO EXTENDING 3 STORIES BELOW GRADE. THE TRIANGULAR TRANSFER OF LOAD AROUND THE ATRIUM PROVIDES AN ELEMENT OF STRUCTURAL COMPLEXITY UNSEEN IN RECTILINEAR BUILDINGS. ARNOLD BUILDING HOUSES THE PUBLIC HEALTH SCIENCE DEPARTMENT OF THE FRED HUTCHINSON CANCER RESEARCH CENTER. FHCRC SPECIFIED THAT THE BUILDING BE DESIGNED TO A STANDARD OF STRUCTURAL INTEGRITY HIGHER THAN THAT OF THE CODE.

FOUNDATION

THE FOUNDATION OF THE PUBLIC HEALTH SCIENCES BUILDING CONSISTS MAINLY OF SPREAD FOOTINGS AND WALL FOOTINGS. WHERE THE FOUNDATION IS REQUIRED TO RESIST LATERAL LOADS CARRIED DOWN BY SHEAR WALLS, THE BUILDING USES DEEPER DRILLED PIERS. THE AVERAGE FOOTING IS ABOUT 12 FEET SQUARE, HOWEVER, SIZES RANGING FROM EIGHT FEET SQUARE TO 28 FEET BY 24 FEET. THE DEPTH RANGES FROM 30 INCHES TO 48 INCHES DEEP, BUT IS TYPICALLY AROUND 40 INCHES DEEP.

FRAMING

THE FRAMING OF ARNOLD BUILDING IS MAINLY COMPOSED OF CONCRETE STRUCTURAL ELEMENTS, HOWEVER, THERE ARE SOME PORTIONS OF THE BUILDING WHERE STEEL HAS BEEN USED. STEEL FRAMING WAS USED FOR THE STAIRS AND SKYLIGHT IN THE ATRIUM. A SPECIAL STIPULATION WAS MADE BY THE STRUCTURAL ENGINEERS THAT THE STRUCTURE OF THE ATRIUM BE DESIGNED SUCH THAT IT WOULD NOT CAUSE ANY TORSIONAL LOAD ON THE REST OF THE BUILDING. THE COLUMNS ON THE FIFTH STORY ARE MADE OF TUBE STEEL WITH THE TYPICAL SIZE BEING TS 12x12x⁵/₈. STEEL WAS ALSO EMPLOYED IN THE DESIGN OF THE ROOF STRUCTURE THAT HOUSES THE BUILD-

ING'S MECHANICAL EQUIPMENT. THE TYPICAL STEEL COLUMN IN THIS AREA IS A TS 4x4x4^{1/4}. THE IRREGULARITY OF THE STEEL ROOF STRUCTURE LENDS ITSELF TO ATYPICAL BEAM AND GIRDER SIZES. THEY RANGE FROM W 10x12 TO W 30x132. THERE ALSO ARE A FEW STEEL COLUMNS IN THE MAIN STRUCTURE.

ALMOST ALL OF THE REMAINING PORTIONS OF THE STRUCTURE ARE MADE OF CONCRETE. THE COLUMNS ARE CONTINUOUS CAST IN PLACE REINFORCED CONCRETE COLUMNS. THE TYPICAL COLUMNS ARE 24 INCHES SQUARE AND ARE ON AN AVERAGE GRID OF 30 FEET BY 30 FEET. THE COLUMNS DO NOT TAPER TOWARDS THE TOP, HOWEVER, THE AMOUNT OF REINFORCEMENT CAN VARY. THE SHAPE OF SOME COLUMNS VARIES. ON CERTAIN FLOORS, COLUMNS HAVE A DIAMETER OF 24 INCHES INSTEAD OF A WIDTH OF 24 INCHES. SUPPORTING CAMPUS DRIVE, THE TURNAROUND, AND THE ENTRANCE PLAZA, UNDER WHICH THE BUILDING EXTENDS, IS AN AREA OF THE BUILDING WHICH USES CAST IN PLACE REINFORCED CONCRETE. THE AVERAGE BEAM SIZE IS 24 INCHES WIDE BY 30 INCHES DEEP.

STRUCTURAL SLABS

THE FLOOR SYSTEM OF ARNOLD BUILDING IS MAINLY COMPOSED OF TWO WAY POST-TENSIONED CONCRETE FLOOR SLABS. THE SLAB IN THE BASEMENT IS NOT POST-TENSIONED BUT INSTEAD IS MADE OF FIBER REINFORCED CONCRETE. THE PORTION OF THE BUILDING THAT IS UNDER THE ENTRANCE PLAZA USES REINFORCED CONCRETE SLABS. THE ROOF SLAB IS COMPOSED OF REINFORCED CONCRETE. WITH THE NOTED EXCEPTIONS THE TYPICAL FLOOR SYSTEM IS A FLAT POST-TENSIONED CONCRETE SLAB WITH DROP PANELS.

LATERAL FORCE RESISTING SYSTEM

FOR THE PURPOSES OF THIS REPORT IT HAS BEEN ASSUMED THAT LATERAL FORCES ARE RESISTED SOLELY BY THE SHEAR WALLS AND BRACED FRAMES THAT ARE PRESENT IN THE STRUCTURE. LOCATED ON THE MECHANICAL LEVEL IS A LATERAL SYSTEM OF BRACED FRAMES WHICH TRANSFER THE LOAD DIRECTLY TO THE SHEAR WALLS. FURTHER ASSUMPTIONS HAVE BEEN MADE IN THE ANALYSIS OF LATERAL LOADS.

EXISTING FLOOR SYSTEM

THE EXISTING TYPICAL FLOOR FRAMING SYSTEM FOR THE FHCRC'S ARNOLD BUILDING IS A TWO-WAY, DROP PANEL, POST-TENSIONED CONCRETE SLAB. THE TYPICAL DEPTH OF THE SLAB IS 8 1/2 INCHES. THE DROP PANELS ADD AN ADDITIONAL 7 1/2 INCHES, FOR A TOTAL FLOOR THICKNESS OF 15 1/2 INCHES. THE TYPICAL COLUMNS ARE 24 INCHES SQUARE.

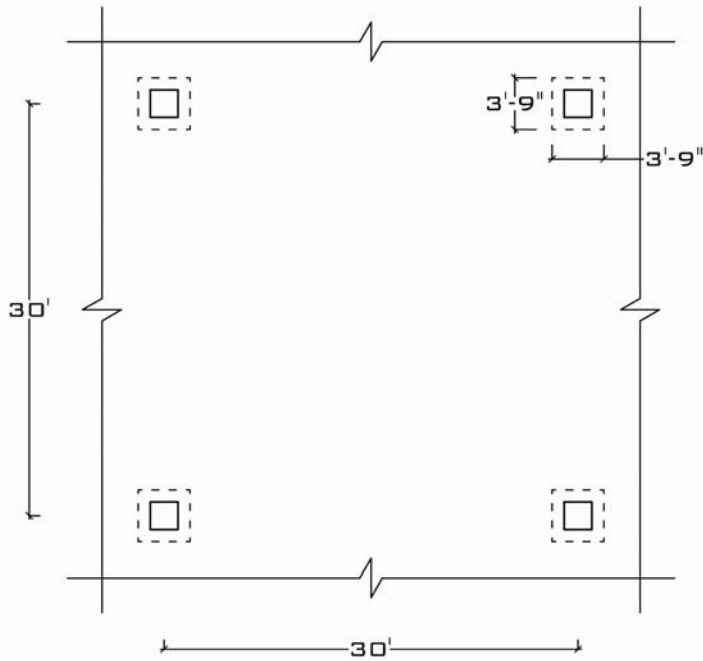

FIGURE 2-1

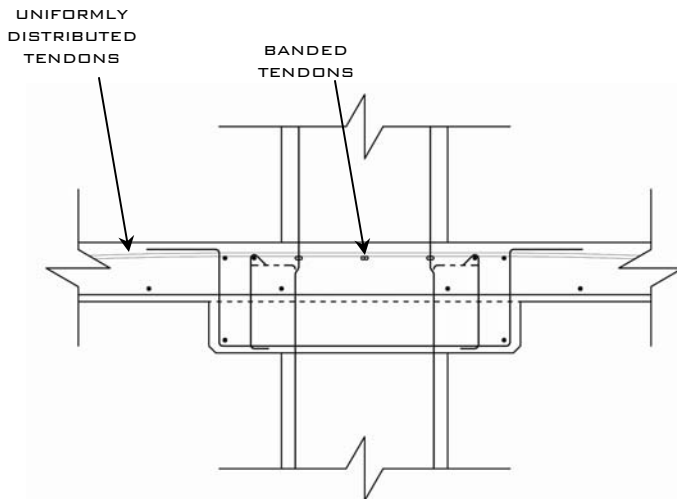

FIGURE 2-2

THE TYPICAL POST-TENSIONING FORCE IN THE DIRECTION PARALLEL TO THE EXTERIOR FACES OF THE BUILDING IS 17.1 KIPS/FT. IN THE PERPENDICULAR DIRECTION, THE TYPICAL JACKING FORCE VARIES SIGNIFICANTLY THROUGHOUT THE BUILDING. THIS VARIATION IS DUE TO IRREGULARITIES IN BOTH THE FRAMING SYSTEM AND THE LOADING CONDITIONS. THE PRE-STRESSING IN THIS DIRECTION CAN VARY ANYWHERE FROM AS LOW AS 80 KIPS TO OVER 910 KIPS. THESE CONCENTRATED FORCES ARE LOCATED AT THE FACES OF THE SUPPORTS. PARALLEL TO THE BANDED PRE-STRESSING TENDONS THERE ARE TEMPERATURE TENDONS TO HELP MINIMIZE CRACKING IN THE SLAB. THE TEMPERATURE TENDONS HAVE NO VARIATION IN PROFILE AND ARE SPACED AT 6 INCHES ON CENTER. THE UNIFORMLY

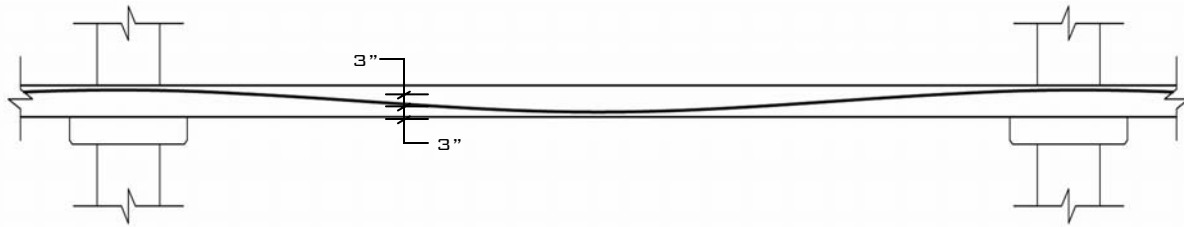

FIGURE 2-3

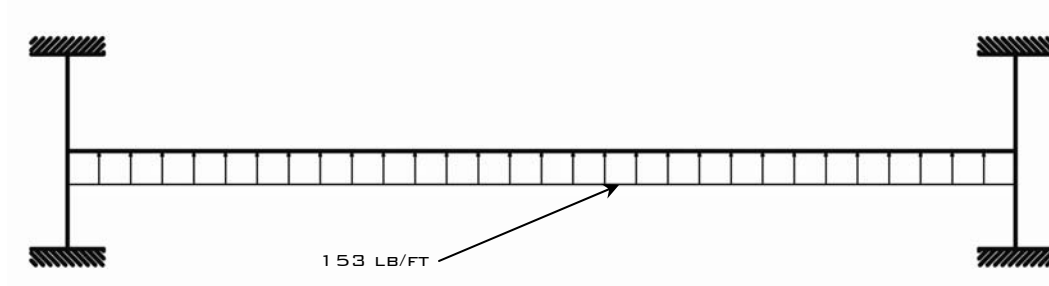

FIGURE 2-4

DISTRIBUTED TENDONS HAVE A SINUSOIDAL PROFILE AS SHOWN IN FIGURE 2-3. AT THE SUPPORTS THE TENDONS ARE LOCATED 7 1/2 INCHES FROM THE BOTTOM OF THE SLAB; MID-SPAN THE TENDONS ARE LOCATED 1 1/2 INCHES FROM THE BOTTOM OF THE SLAB. THIS PRODUCES A 3 INCH ECCENTRICITY, MID-SPAN AND AT THE SUPPORT, FROM THE CENTER OF THE SLAB. ACCORDING TO THE LOAD BALANCING METHOD OF ANALYSIS FOR PRE-STRESSED MEMBERS THE EVENLY DISTRIBUTED TENDONS INDUCE A LOAD CAPABLE OF BALANCING 153 POUNDS PER FOOT OF SLAB WIDTH DEPICTED IN FIGURE 2-4

THERE IS A CERTAIN AMOUNT OF TRADITIONAL REINFORCEMENT IN THE FLOOR SYSTEM. THE SECTION OF THE DROP PANEL IN FIGURE 2-2 SHOWS STEEL REBAR REINFORCEMENT AS SOLID, WHILE THE POST-TENSIONING REINFORCEMENT IS ONLY AN OUTLINE.

FIGURE 2-5

ALTERNATE SYSTEM 1: COMPOSITE CONSTRUCTION

THE FIRST ALTERNATIVE FLOOR SYSTEM THAT WAS INVESTIGATED WAS COMPOSITE CONSTRUCTION. THE DESIGN CALCULATIONS FOR THE COMPOSITE SYSTEM MAY BE FOUND IN APPENDIX 1. STEEL DECK WAS CHOSEN USING A TABLE FROM VULCRAFT'S MANUFACTURING SPECIFICATIONS. ALTHOUGH LIGHTER DECKS WOULD BE ABLE TO SPAN THE 10 FOOT SPACING OF BEAMS,

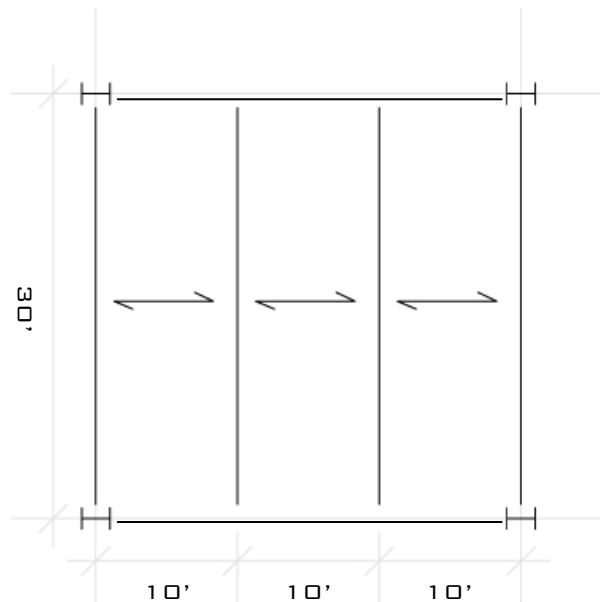

FIGURE 2-6

THE 3VLI18 DECK WITH 5 1/2 CONCRETE SLAB WAS CHOSEN BECAUSE IT CAN SPAN 10 FEET WITHOUT ANY SHORING. THIS CHOICE ELIMINATES BOTH THE MATERIAL AND LABOR COSTS OF SHORING. EACH BEAM WILL REQUIRE 38 SHEAR STUDS FOR THE DESIGNED COMPOSITE ACTION. THE BEAMS [FIGURE 2-7] ARE W14X22'S; THEY ARE SPACED TEN FEET ON CENTER AND SPAN 30 FEET WHICH IS SHOWN IN FIGURE 2-6. THE

SUPPORTING GIRDERS BOTH SPAN AND ARE SPACED AT 30 FEET. THE CROSS SECTION OF THESE GIRDERS ARE DEPICTED IN FIGURE 2-8. THESE MEMBERS WERE DESIGNED TO BE W24X55S AND REQUIRE 32 SHEAR STUDS EACH.

THE DEPTH OF THE PROPOSED FLOOR SYSTEM IS SLIGHTLY GREATER THAN 29 INCHES. THIS DOES NOT ACCOUNT FOR ANY ALLOWANCES FOR MECHANICAL DUCTWORK OR ELECTRICAL CONDUIT. THIS HAS SIGNIFICANT IMPLICATIONS ON THE ARCHITECTURAL DESIGN OF THE BUILDING. EITHER THE FLOOR TO CEILING HEIGHT WILL NEED TO BE ALTERED OR THE OVERALL BUILDING HEIGHT WILL NEED TO BE MODIFIED.

BY INTRODUCING STEEL MEMBERS, INTO THE DESIGN FIRE PROTECTION IS OF GREATER CONCERN. THE STRUCTURAL FRAME WILL NEED TO BE PROTECTED BY SOME SORT OF FIRE PROOFING. THERE ARE A VARIETY OF FIRE RATED CONSTRUCTIONS THAT CAN MAKE THE SYSTEM MEET THE SPECIFIED FIRE REQUIREMENTS. SPRAY ON FIRE PROOFING OR GYPSUM WALLBOARD COULD EACH

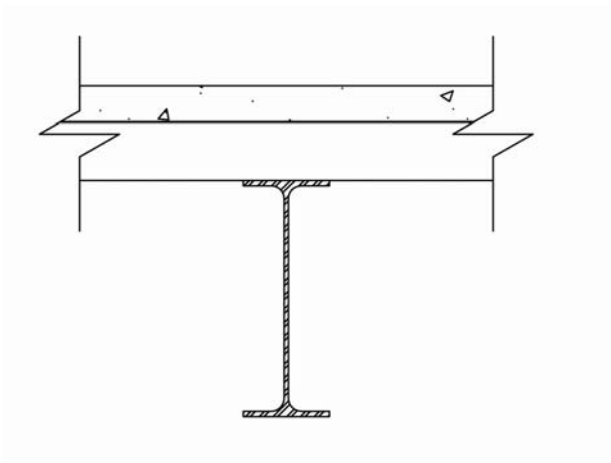

FIGURE 2-7

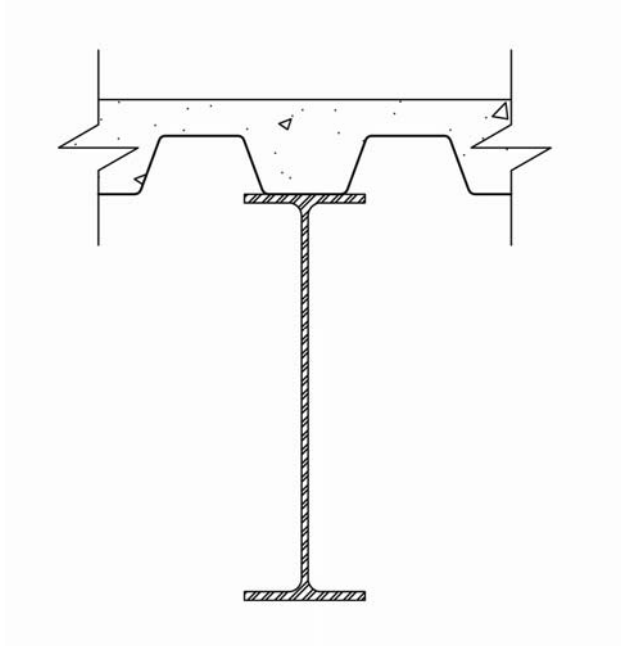

FIGURE 2-8

ACHIEVE THE NECESSARY RATING.

FOR THIS PROPOSED FLOOR CONSTRUCTION THE WEIGHT OF A SINGLE BAY IS 48.63 KILO POUNDS, WHICH IS NEARLY HALF THE WEIGHT OF THE EXISTING FLOOR SYSTEM WHICH IS 96.94 KILO POUNDS. THESE CALCULATED WEIGHTS ARE STRICTLY THE STRUCTURAL FLOOR SYSTEM. CONSEQUENTLY THEY NEGLECT COLUMNS AND SUPERIMPOSED DEAD LOADS, WHICH ARE ASSUMED TO REMAIN THE SAME FOR ALL OF THE DISCUSSED FLOOR SYSTEMS. A REDUCTION IN BUILDING WEIGHT COULD POTENTIALLY REDUCE THE SIZE OF THE FOUNDATION. A REDUCTION IN BUILDING WEIGHT IMPLIES A REDUCTION IN BUILDING MASS. SINCE SEISMIC LOADS ARE A FUNCTION OF BUILDING MASS THE LATERAL FORCE RESISTING SYSTEM COULD ALSO BE REDESIGNED TO USE LESS CONCRETE AND THEREFORE LOWERING MATERIAL COSTS.

THE CONSTRUCTABILITY OF A COMPOSITE DESIGN DOES NOT POSE MANY PROBLEMS. MINIMAL FORM WORK WOULD BE NECESSARY FOR END SPANS. AS NOTED EARLIER, THE SYSTEM WOULD NOT REQUIRE SHORING OF THE METAL DECK. THE STEEL MEMBERS COULD BE QUICKLY AND EASILY ERECTED. ONE DISADVANTAGE WOULD BE THE LABOR INTENSIVE PLACEMENT OF SHEAR STUDS. HOWEVER THE EXISTING SYSTEM REQUIRED WAITING FOR THE CONCRETE TO CURE AND POST TENSIONING COSTS. A PRELIMINARY CALCULATION OF THE DIFFERENCE IN COSTS OF THE PROPOSED SYSTEM REVEALS THAT IT IS \$9400 PER

ALTERNATE SYSTEM 2: PRE-CAST PRE-STRESSED CONSTRUCTION

THE SECOND ALTERNATIVE FLOOR SYSTEM INVESTIGATED WAS PRE-CAST & PRE-STRESSED CONCRETE CONSTRUCTION. THE 12 INCH DEEP SPANDECK [FIGURE 2-10] BY NITTERHOUSE CONCRETE PRODUCTS WAS CHOSEN, HOWEVER, OTHER MANUFACTURERS HAVE COMPARABLE PRODUCTS. A TWO INCH TOPPING WILL BE PLACED ON THE DECK AND IT HAS A STRAND PATTERN OF (6)

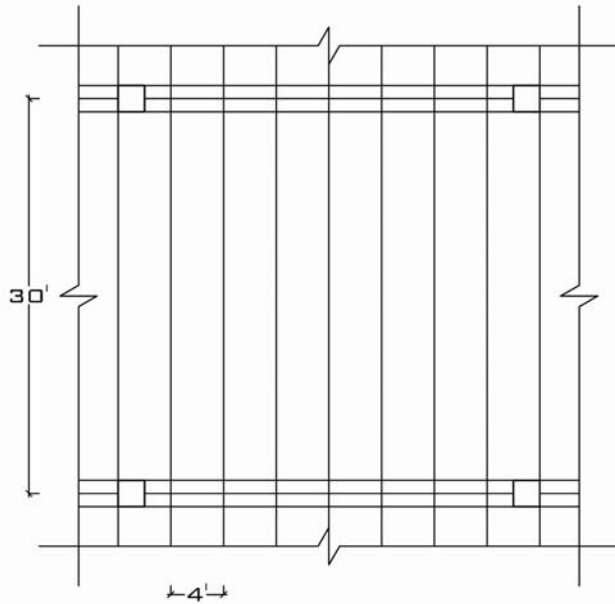

FIGURE 2-9

1/2 INCH DIAMETER STRANDS. EACH PANEL OF SPANDECK IS FOUR FEET WIDE. FIGURE 2-9 SHOWS A TYPICAL FRAMING LAYOUT. THE PRE-STRESSED DECK WILL BE SUPPORTED BY RECTANGULAR BEAMS THAT SPAN FROM COLUMN TO COLUMN. THE BEAMS ARE 16RB40'S [FIGURE 2-11] WHICH WERE DESIGNED USING A TABLE FOUND IN THE PCI HANDBOOK [APPENDIX 3]. THE TOTAL DEPTH OF THE PRE-CAST FLOOR SYSTEM IS 54 INCHES. THIS IS A DRAMATIC INCREASE FROM THE ORIGINAL FLOOR SYSTEM'S DEPTH OF 16 INCHES. THE MAIN ADVANTAGE OF USING A PRE-CAST SYSTEM IS ITS CONSTRUCTABILITY. THE MEMBERS CAN BE MANUFACTURED, TRANSPORTED TO THE SITE, AND ERECTED MUCH MORE QUICKLY THAN OTHER SYSTEMS.

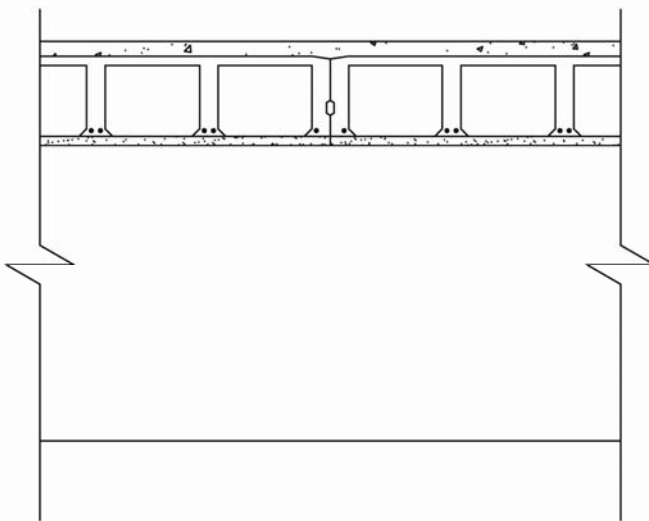

FIGURE 2-10

CONCERNING FIRE RATINGS THE SYSTEM WILL BE ACCEPTABLE. WITH THE SPECIFIED 2 INCH TOPPING THE SYSTEM

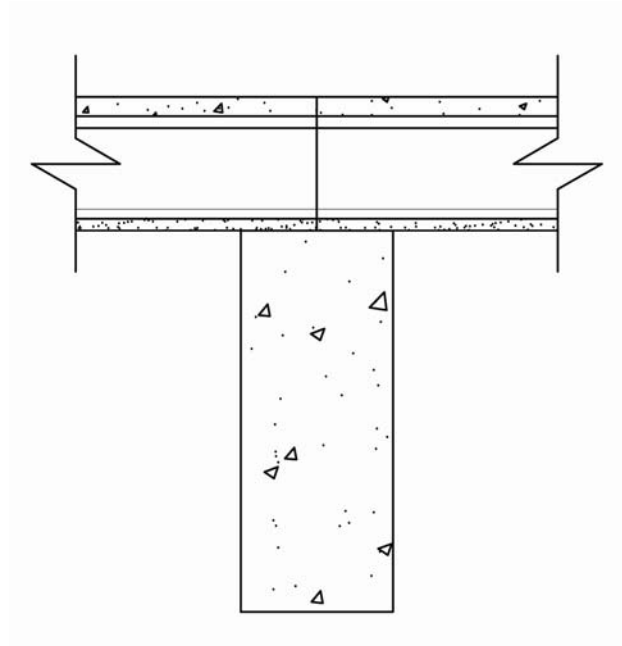

FIGURE 2-11

ACHIEVES A 3 HOUR RATING.

OTHER DESIGN IMPLICATIONS OF A PRE-CAST SYSTEM THAT MUST BE CONSIDERED ARE THOSE REGARDING THE SEISMIC LOADING AND FOUNDATION DESIGN. THE WEIGHT OF THE PROPOSED SYSTEM IS 112.3 KILO POUNDS, ABOUT A 16% INCREASE FROM THE 96.9 KILO POUND EXISTING SYSTEM. DUE TO THIS INCREASE IN WEIGHT THE FOUNDATION WOULD HAVE TO BE DESIGNED TO SUPPORT THIS ADDED LOAD. AS AN INCREASE IN WEIGHT IMPLIES AN INCREASE IN MASS, THE LATERAL SYSTEM WOULD ALSO INCUR SIGNIFICANT DESIGN CHANGES. BOTH CHANGES TO THE FOUNDATION AND CHANGES TO THE LATERAL FORCE RESISTING SYSTEM WOULD GENERATE A SIGNIFICANT INCREASE IN COST, HOWEVER, THE COST OF THE ACTUAL FLOOR SYSTEM IS COMPARABLE TO THE EXISTING.

ALTERNATE SYSTEM 3: CAST IN PLACE (ONE-WAY) CONCRETE FLOOR SYSTEM

THE THIRD PROPOSED SYSTEM IS A CAST IN PLACE CONCRETE FLOOR SYSTEM. THIS SYSTEM IS MADE UP OF A ONE-WAY SLAB WITH BEAMS AND GIRDERS. THIS CONCRETE SYSTEM HAS A SLAB THICKNESS OF 8 INCHES. THE BEAMS ARE 24 INCHES WIDE AND 20 INCHES DEEP, WHILE, THE GIRDERS [FIGURE 2-

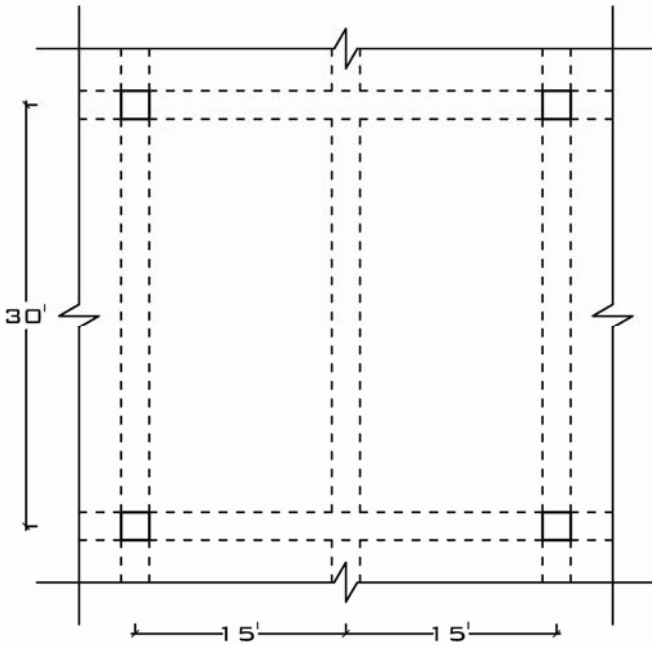

FIGURE 2-12

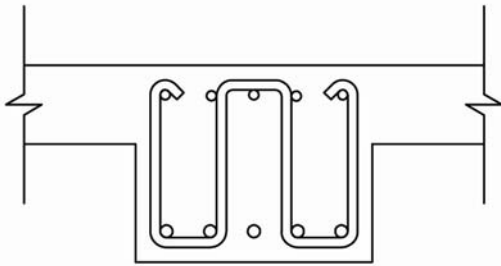

FIGURE 2-13

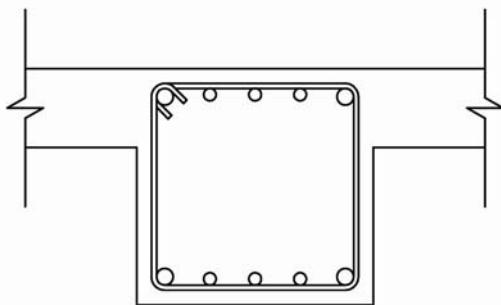

FIGURE 2-14

14] ARE 24 INCHES SQUARE IN CROSS SECTION. ALTHOUGH THE BEAM CROSS SECTION IN FIGURE 2-13 SHOWS BOTH TOP AND BOTTOM REINFORCEMENT THE BEAMS ARE DESIGNED TO ACT AS SINGLY REINFORCED. FIGURE 2-16B SHOWS WHERE THE REINFORCEMENT IS DISCONTINUOUS. THE MOMENT COEFFICIENTS SPECIFIED BY ACI WERE USED IN CALCULATING THE REQUIRED MOMENT CAPACITY OF THE BEAMS. THE MOMENTS USED WERE THOSE FOR AN EXTERIOR SPAN BECAUSE THESE WOULD CONTROL THE DESIGN OF THE BEAMS. SINCE INTERIOR SPANS ARE SUBJECTED TO MORE BALANCED LOAD CONDITIONS THESE BEAMS COULD BE MORE EFFICIENTLY DESIGNED. THE BEAMS REQUIRE #8 STIRRUPS, A SIGNIFICANT AMOUNT OF SHEAR REINFORCEMENT. THE GIRDERS ON THE OTHER HAND REQUIRE ONLY #4 STIRRUPS. FIGURES 2-15B AND 2-16B SHOW WHERE SHEAR REINFORCEMENT IS DISCONTINUED IN ORDER TO USE THE PROPOSED SYSTEM IT WOULD BE ADVANTAGEOUS TO REFINES THE DESIGN IN ORDER TO REDUCE THE AMOUNT OF NECESSARY SHEAR REINFORCEMENT.

WITH REGARDS TO FIRE RESISTANCE THIS PROPOSED SYSTEM MEETS THE MINIMUM REQUIREMENTS. A CAST IN PLACE CONCRETE

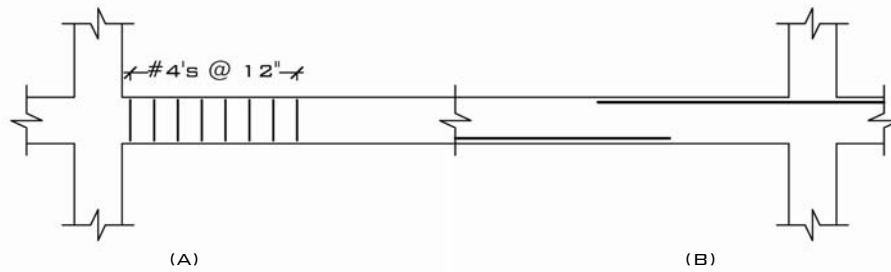

FIGURE 2-15

SLAB WITH BEAMS AND GIRDERS WITH A SLAB 6.6 INCHES THICK REQUIRES A MINIMUM OF 3/4 INCH COVER ON REINFORCEMENT TO ACHIEVE A FIRE RATING OF 4 HOURS. THE COVER FOR THIS DESIGN IS 1 1/2 INCHES AND THEREFORE MEETS THESE MINIMUM REQUIREMENTS.

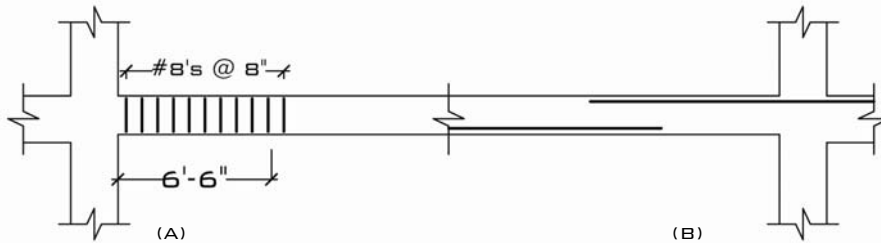

FIGURE 2-16

THE OVERALL DEPTH OF THE FLOOR SYSTEM HAS SIGNIFICANT DESIGN IMPLICATIONS AS MENTIONED IN THE PREVIOUS PROPOSED SYSTEMS. THE OVERALL DEPTH OF THE SYSTEM IS 24 INCHES DEEP, THE DEPTH OF THE GIRDER. THIS IS SIGNIFICANTLY LARGER THAN THE EXISTING 16 INCH DEPTH BUT DOES NOT COME CLOSE TO THE PRE-CAST SYSTEM DEPTH OF 54 INCHES. THE DIFFERENCE BETWEEN THIS FLOOR DESIGN AND THE EXISTING ONE MAY BE MANAGEABLE, AND MAY BE REDUCED WITH FURTHER DEVELOPMENT OF THE DESIGN.

POTENTIAL CHANGES TO OTHER AREAS OF THE STRUCTURAL SYSTEM IN THE BUILDING MUST BE TAKEN INTO CONSIDERATION. THE PROPOSED FLOOR SYSTEM DESIGN PRODUCES APPROXIMATELY AN 11% INCREASE IN BUILDING WEIGHT. THE FOUNDATION WOULD NEED TO ACCOMMODATE THIS CHANGE IN THE DESIGN LOADS. BEING DEPENDANT ON BUILDING MASS THE LATERAL SYSTEM WOULD ALSO BE GREATLY AFFECTED. STORY SHEARS AND BUILDING BASE SHEAR WOULD ALL INCREASE SIGNIFICANT AMOUNTS. AS A RESULT DIRECT RESULT OF THE REDESIGN OF THESE PARTS OF THE STRUCTURAL SYSTEM CONSTRUCTION COSTS WOULD ALSO INCREASE.

THE COST OF MATERIALS AND LABOR OF A CAST IN PLACE CONCRETE FLOOR SYSTEM WOULD BE ABOUT \$14,000 PER BAY. THIS IS SLIGHTLY MORE THAN THE EXISTING SYSTEM. BOTH FORMWORK AND CURING TIME ARE IMPORTANT CONSIDERATIONS REGARDING CONSTRUCTABILITY. SINCE THE EXISTING SYSTEM WOULD REQUIRE SIMILAR AMOUNTS OF FORMWORK AND CURING TIME IT IS NOT A SIGNIFICANT CONCERN.

ALTERNATE SYSTEM 4: TWO-WAY DROP PANEL SLAB CONSTRUCTION

THE FOURTH AND FINAL ALTERNATE SYSTEM BEING PROPOSED IS A CAST IN PLACE TWO-WAY DROP PANEL SYSTEM. THIS SYSTEM WAS DESIGNED USING A TABLE FROM THE CRSI MANUAL, WHICH MAY BE FOUND IN APPENDIX 6. IT USES OLDER LOAD FACTORS BUT THEY ARE STILL ACCEPTABLE TO ACI SPECIFICATIONS, WHICH PRODUCE A MORE CONSERVATIVE DESIGN. A TYPICAL BAY IS

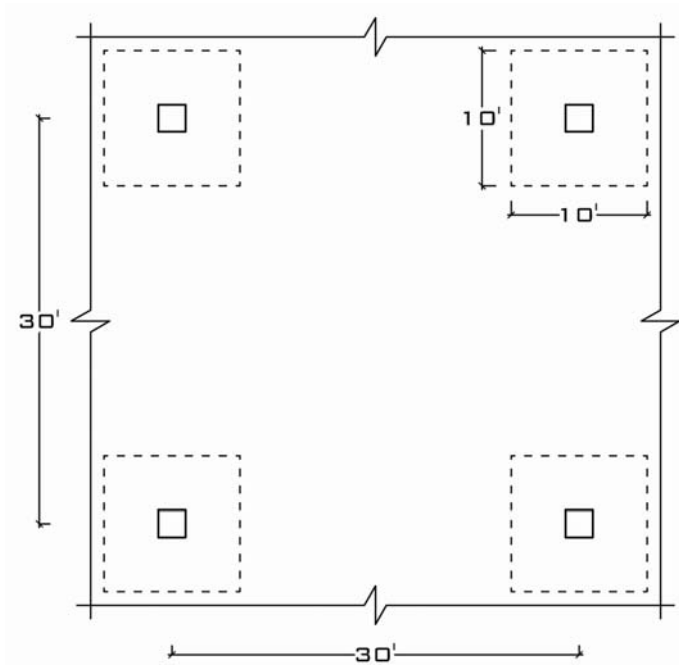

FIGURE 2-17

DEPICTED IN FIGURE 2-17. THE DROP PANELS ARE 10 FEET SQUARE AND EXTEND 7 INCHES BELOW THE 11 INCH SLAB. FIGURE 2-18 SHOWS A TYPICAL DETAIL OF THE DROP PANEL IN SECTION.

THE TOTAL DEPTH OF THE SYSTEM IS THEN 18 INCHES. THIS IS THE CLOSEST OF THE PROPOSED SYSTEMS TO THE EXISTING SYSTEM'S DEPTH OF 16 INCHES. IT IS UNDERSTANDABLE THAT THE EXISTING SYSTEM IS THINNER. ONE OF THE MAIN ADVANTAGES OF POST-TENSIONING IS A REDUCTION IN FLOOR SYSTEM DEPTH.

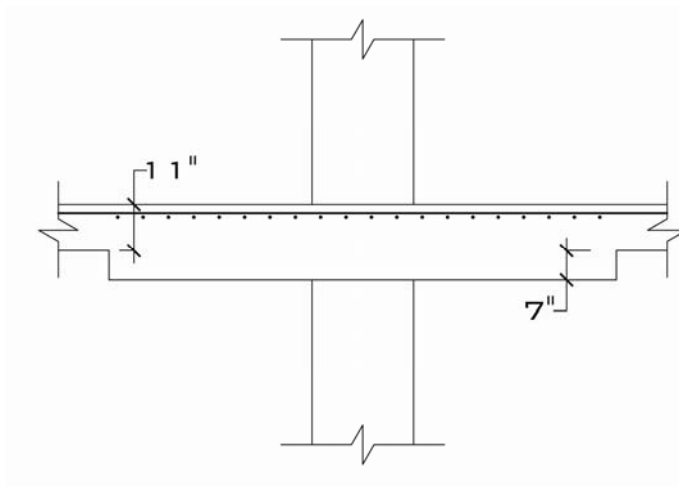

FIGURE 2-18

THE TOTAL WEIGHT OF THE SYSTEM IS 132.4 KIPS WHICH IS THE HEAVIEST SYSTEM EXPLORED THUS FAR. THIS IS A 38% INCREASE FROM THE EXISTING SYSTEM. SUCH A DRAMATIC INCREASE IN FOUNDATION AND LATERAL LOADS MAKE THIS SYSTEM LESS ATTRACTIVE.

THE COST OF SUCH A SYSTEM IS COMPARABLE TO THE EXIST-

ING. WHILE THE COST OF POST-TENSIONING HAS BEEN ELIMINATED IN THIS DESIGN, THERE IS ALSO A SIGNIFICANT INCREASE IN THE AMOUNT OF CONCRETE REQUIRED FOR THE DESIGN.

REGARDING CONSTRUCTABILITY THE EXISTING SYSTEM REQUIRED SIMILAR AMOUNTS OF FIELD WORK, EXCLUDING THAT RELATED TO POST-TENSIONING, AS THE PROPOSED SYSTEM DOES. THE AMOUNTS OF LABOR MAY BE RELATIVELY SIMILAR BUT THERE WOULD BE MORE FORMWORK. IN ADDITION TO THE ADDED FORMWORK, THE INCREASE IN CUBIC YARDS OF CONCRETE WOULD WARRANT A GREATER AMOUNT OF SHORING DURING THE CONSTRUCTION PHASE.

COMPARISON OF FLOOR SYSTEMS

THE EXISTING TWO-WAY POST-TENSIONED SLAB APPEARS TO BE ONE OF THE BETTER SYSTEMS. POST-TENSIONING ALLOWS THIS CONSTRUCTION TO HAVE THE SMALLEST DEPTH. PUNCHING SHEAR REQUIRES THERE TO BE DROP PANELS AT THE COLUMN LOCATIONS. THE OTHER MAIN ADVANTAGE TO THIS SYSTEM IS A RESULT OF THE FLOOR THICKNESS BEING MINIMIZED. THIS ADVANTAGE IS THE SELF WEIGHT OF THE SYSTEM. THE EXISTING FLOOR CONSTRUCTION IS ONE OF THE LIGHTER SYSTEMS. EVEN THOUGH THE EXISTING SYSTEM IS A WELL SUITED CHOICE ALTERNATIVES WERE EXPLORED. TABLE 2-3 IS PROVIDED A COMPARISON OF EACH OF THE FLOOR SYSTEMS.

COMPARISON OF FLOOR SYSTEMS

SYSTEM	FIRE RATING	WEIGHT/ MASS [KIPS]	COST [\$ /BAY]	DEPTH OF SYSTEM [INCHES]	CONSTRUCTABILITY
2-WAY POST-TENSIONED (EXISTING)	✓	96.9	12500	15.5	FAIR
COMPOSITE	✗	48.6	9400	29	VERY GOOD
PRE-CAST CONCRETE	✓	112.3	13573	54	VERY GOOD
CAST-IN-PLACE 1-WAY	✓	107.9	14000	24	FAIR
CAST-IN-PLACE 2-WAY W/ DROP PANELS	✓	132.4	11600	18	GOOD

TABLE 2-3

THE CAST IN PLACE TWO WAY SLAB WITH DROP PANELS CAN QUICKLY BE ELIMINATED. THE DEPTH OF THIS SYSTEM IS CLOSE TO THAT OF THE EXISTING SYSTEM, BUT IT IS THE HEAVIEST SYSTEM EXPLORED. THE ADDITIONAL DEAD WEIGHT'S IMPACT ON THE FOUNDATION AND LATERAL FORCE RESISTING SYSTEM MAKE IT IMPRACTICAL TO EXAMINE THIS SYSTEM ANY FURTHER.

THE PRE-CAST, PRE-STRESSED FLOOR SYSTEM HAS THE ADVANTAGE OF CONSTRUCTABILITY. THE EASE OF ASSEMBLY AND ACCELERATED CONSTRUCTION SCHEDULE ARE ATTRACTIVE ADVANTAGES OF THIS SYSTEM. THIS BEING SAID, THE DEPTH AND WEIGHT OF THE SYSTEM CANNOT BE OVERLOOKED. THERE ARE OTHER OPTIONS WITH A PRE-CAST/PRE-STRESSED SYSTEM THAT

COULD BE EXAMINED. CUSTOM MEMBERS COULD BE ORDERED, BUT THE ECONOMICS WOULD BE DEPENDENT ON THE REPETITION OF THESE MEMBERS IN THE BUILDING.

THE ONE-WAY CAST IN PLACE CONCRETE FLOOR SYSTEM IS A SLIGHTLY BETTER OPTION THAN THE TWO-SYSTEM (WITHOUT POST-TENSIONING). THE ONE-WAY SYSTEM USES FEWER CUBIC YARDS OF CONCRETE THAN THE TWO-WAY SYSTEM, HOWEVER, IT WOULD REQUIRE A GREATER AMOUNT OF FORMWORK AND LABOR.

THE COMPOSITE FLOOR FRAMING HAS THE ADVANTAGE OF BEING THE LIGHTEST, HOWEVER, IT IS ALSO SIGNIFICANTLY DEEPER THAN THE EXISTING FLOOR SYSTEM. THE CONSTRUCTABILITY OF THIS SYSTEM IS ALSO AN IMPORTANT ADVANTAGE. WHILE ADDED LABOR FOR THE SHEAR STUDS WILL BE NEEDED NO SHORING WILL BE REQUIRED. THIS MEANS THAT THE FLOOR ABOVE CAN BE POURED IMMEDIATELY AFTER THE FLOOR BELOW. THE CONSTRUCTION SCHEDULE IS INDEPENDENT ON THE CURING OF THE CONCRETE OF THE PREVIOUS FLOOR.

FURTHER INVESTIGATIONS INTO ALTERNATIVE FLOOR SYSTEMS SHOULD EXPLORE OTHER WAYS TO APPLY COMPOSITE CONSTRUCTION. COMPOSITE SYSTEMS HAVE THE POTENTIAL TO BE SHALLOW AND LIGHT WHILE REMAINING STIFF ENOUGH TO LIMIT DEFLECTIONS AND OTHER DEFORMATIONS TO AN ACCEPTABLE LEVEL. WHILE DEFLECTIONS WERE NOT CONSIDERED IN THE DESIGN OF THE SYSTEMS THEY WILL EVENTUALLY NEED TO BE CHECKED.